

Ascension[®]

P A Y P H O N E S

AE Style User's Guide



Innovation is our business

Ascension[®]
AE Style
User's Guide



Innovation is our business

Notices

Before using your *Ascension*[®] smart payphone, be sure to read the general safety information on page 2.

Ascension[®], *ExpressNet*[®], *ExpressNet III*[®] and *Protel*[®] are registered trademarks of Protel, Incorporated.

Panorama[™] is a tradename of Protel, Inc.

Abloy[®] is a registered trademark of Abloy Security, Inc. *Coinco*[®] is a registered trademark of Coin Acceptors, Inc. *Imonex*[®] is a registered trademark of Imonex Services, Inc. *Medeco*[®] is a registered trademark of Medeco Security Locks, Inc. All other trademarks are those of their respective companies and are hereby acknowledged.

This publication could include technical inaccuracies or typographical errors. Changes are periodically made to the information herein; these changes will be incorporated in new editions of the publication. Protel may make improvements or changes in the products described in this publication at any time.

Warranty

PROTEL, INC. (PROTEL) warrants that all products that it manufactures shall operate in accordance with published specifications. Products shall be free from defects in material and workmanship for the warranty period, which begins on the date of shipment.

THE LIMITED WARRANTY EXPRESSED HEREIN IS THE SOLE AND EXCLUSIVE WARRANTY PROVIDED BY PROTEL. PROTEL MAKES NO OTHER WARRANTY, EITHER EXPRESSED OR IMPLIED, OF ANY KIND INCLUDING WITHOUT LIMITATION ANY WARRANTY OR MERCHANTABILITY, FITNESS FOR A PARTICULAR PURPOSE, TITLE OR LACK OF INFRINGEMENT.

THE CORRECTION OF ANY DEFECTS BY REPAIR OR REPLACEMENT WITHIN THE WARRANTY PERIOD SHALL CONSTITUTE THE SOLE AND EXCLUSIVE REMEDY OF PURCHASER AND SHALL CONSTITUTE THE FULFILLMENT OF THE ENTIRE OBLIGATION OF PROTEL WITH RESPECT TO ANY WARRANTY GIVEN HEREIN. PROTEL SHALL NOT BE LIABLE TO PURCHASER OR ANY THIRD PARTY FOR LOSS OF PROFITS, DIRECT, INDIRECT, SPECIAL OR CONSEQUENTIAL, OR OTHER DAMAGES FROM ANY CAUSE WHATSOEVER.

Repair

Protel, Inc. will repair or replace any product of its manufacture. All requests for such repair should be directed to PROTEL Customer Service Department (800) 925-8882. In-warranty repair is free of charge, freight prepaid. Out-of-warranty repair is handled on a labor-plus-parts basis.

Table of Contents

Notices ii

Warranty ii

Repair ii

Table of Contents iii

Introduction 1

Introducing the *Ascension* 1
General Description 1
Safety Information 2

Telephone Components 2

Ascension Telephone Housing 2
Construction of the *Ascension* Telephone 2
Form & Fit of the *Ascension* Telephone 3
Coin Box w/Lid 3
Vault Door 3
Vault Door Lock 4
Vault Door Alarm Switch 4
Terminal Block 4
Electronic Chassis 4
Coin Mechanism 4
Dual Solenoid Actuator/Hopper and Coin Return Chute Assembly 4
Trigger Switch (Not Shown) 4
Latch Assembly 5
Hookswitch Cam/Switch Assembly 5
Upper Housing Lock 5
Coin Entrance 5
Coin Release Push Button Assembly 5
Handset 5
Hookswitch Plate 5
Top Piece 6
Main Bezel 6
Dial Key Components 6
Upper Housing Interconnect Cable 6
Information Card 6
Hookswitch Cradle 6
Dataport Assembly (Optional) 6
Display Components (Not Shown) 6
O-Ring Seal 7
Cast Aluminum Backing Plate 7
Function Key Components 7
Speed Dial Keys 8
Displays 8
Card Reader 8

Mounting the Paystation 9

Mounting Location 9
Leveling the Mounting Surface 9
Mounting the Backboard 10
Separating the Upper and Lower Housings 10
Removing the Coin Validator 10
Removing the Chassis Assembly 11

- Removing the Coin Box 11
- Removing the Escrow Relay/Hopper Assembly 11
- Installing the Security Studs 11
- Securing the Paystation to the Mounting Surface 12
- Reinstalling the Escrow Relay/Hopper Assembly 12
- Reinstalling the Coin Box 12
- Reinstalling the Chassis Assembly 12
- Reinstalling the Coin Validator 13
- Connecting the Line Wire to the Terminal Block 13
- Connecting the External DC Power 14
- Connecting the Upper and Lower Housings Together 15

Appendix A – 7000C Chassis 16

Appendix B – Data Port Installation 17

- Installing the Data Port Assembly 17
- Replacing the Data Port Assembly 17

Appendix C – Toll Restrictor Installation 17

Appendix D – Spare Parts List 18

Appendix E – Information Card Removal, Installation, and Specifications 19

- Removal of the Information Card 19
- Installation of the Information Card 19
- Basic Dimensions 20
- Speed Dial Button and Display Dimensions 21
- Speed Dial Label Dimensions 21

Appendix F – Handset Replacement and Jumper Settings 22

- Replacing the Handset 22
- Handset Jumper Settings 23

Appendix G – Specifications 25

- Electrical 25
- Hardware 25

Appendix H – Regulatory Information 26

- FCC Registration 26
- Industry Canada Information 27

Appendix I - Programming of Messages for a LCD with No External Power 28

Appendix J - Programming of Messages for a LCD with External Power 29

Appendix K - Programming of messages for a VFD 30

Index 31

Introduction

Introducing the *Ascension*

Protel's revolutionary *Ascension* smart payphone boasts that rare feat of combining truly exquisite form with superior function. Rising above the ordinary to reach new heights, *Ascension's* clean lines and ergonomic layout make it the perfect payphone to install at any location. City sidewalks, retail stores, malls, hotel chains, airports, restaurants, convention centers, colleges and hospitals are all potential sites that allow you to reap the benefits of installing *Ascension*. Its sleek, sophisticated appearance is the ticket to getting into more locations, as well as keeping existing location owners happy.

Ascension is designed for ultimate flexibility. It can be site specific, location specific, account specific or customer specific. This smartphone goes anywhere.

In addition to attracting traditional callers paying with coins, *Ascension's* optional state-of-the-art card readers and data jack encourage use by callers who demand the benefits of the latest technology. Set-based operation eliminates the need for third-party call controllers.

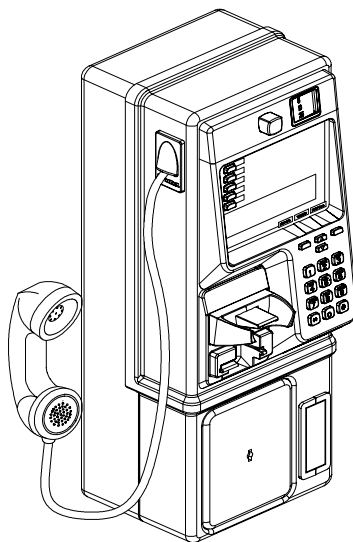

Full-Featured *Ascension*

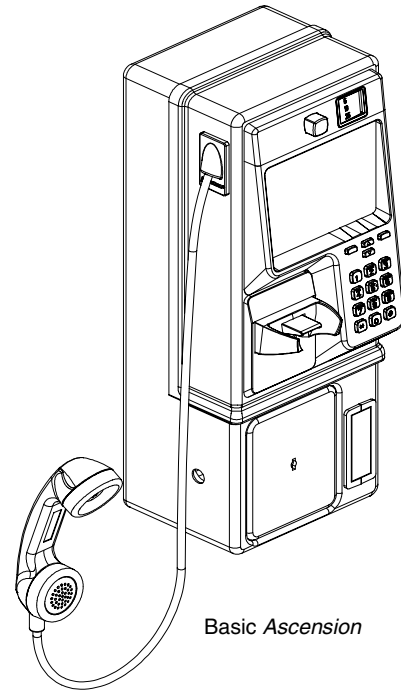

Basic *Ascension*

Intuitive operation is expected from today's payphones and that's what is delivered with *Ascension*. Icons gently guide users with a minimum of direct instruction. Strategically placed feature buttons allow selection of multiple language voice prompts, receiver volume control and next-call function through visual instructions. Larger, wider spaced keys make dialing easier for everyone, especially those with sight impairment or a limited range of hand motion.

The payphone environment can be harsh. In addition to providing maximum security, the *Ascension's* high strength aluminum casting resists corrosion and will maintain its good looks through a lifetime of hard service. A scratch-resistant, polyester powdercoat finish gives the *Ascension* a look to appreciate. O-ring seals resist water to give the *Ascension* a long and reliable service life. All of these features translate into more satisfied customers and less windshield time for service technicians.

The *Ascension* payphone is rising to a new level of style, flexibility, durability and user satisfaction.

Additional features and description can be found on Protel's *Ascension* specification sheet or at www.protelinc.com.

General Description

The feature package of the *Ascension* is provided by station-based intelligence that is compatible with all types of central offices. The *Ascension* permits basic coin service, as well as the use of credit and calling cards with an insertion-type card reader. The same reader accepts a variety of smart cards.

Ascension payphones are compatible with many of Protel's products with respect to coin acceptors, locks, vault doors, cash box switches, and handsets. Language select, up/down volume control, and next call buttons are standard for *Ascension* models.

Ascension payphones are modular in design, and allow customers to add features to the base product as necessary. The customer, if not ordered at the time of original shipment to the customer, may easily install these modular feature upgrades, at any time during the life of the product. Examples of these features are card reading devices, multifunction buttons, and displays.

Safety Information

Quality Assurance and Reliability

Product integrity shall be maintained and there shall be no deviations from physical criteria that may or will adversely affect the product with respect to safety, reliability, interchangeability, life, performance and operation, quality, protectants, maintenance or aesthetics.

The manufacturing processes, tests and inspection procedures, and quality program used by a manufacturer shall be adequate to provide that technical requirements and customer endpoint requirements are met. Quality Assurance criteria are met in this area to cover the ability of the factory testing program to provide product operability and functionality. Details of the quality program criteria are documented in the procedures governed by International Standards. Products shall be manufactured in accordance with the following:

Federal Communications Commission (FCC) Requirements
Electrical Code Requirements, Underwriters Laboratories (UL)
Occupational Safety and Health Standards (OSHA)
All other applicable Federal, State and local requirements consistent with industry standards.

Environmental Requirements

Toxic materials appearing on lists of banned or dangerous materials issued by appropriate government agencies pertaining to devices, components etc., shall not be used in the manufacture of the chassis.

Hazardous Waste Disposal: - Nickel Cadmium Battery upon replacement should not be opened or incinerated. Recycling of the units are recommended.

Storage: - Store in a cool place, but prevent condensation on cell or battery terminals.

Handling: - Accidental short circuit will bring high temperature elevation to the battery as well as shorten the battery life. Be sure to avoid prolonged short circuit since the heat can burn attendant skin and cause rupture.

Telephone Components

Ascension Telephone Housing

The *Ascension's* housing components are engineered and manufactured to improve on the longevity and reliability of traditional paystation equipment. The *Ascension* is a result of Protel's innovation, technology, and drive to create better products to fulfill your public communication needs.

The *Ascension's* housing components are included in the warranty. The housing components are backed by Protel's one-year warranty.

Designed with the use of the latest 3D Computer Aided Design (CAD) software, the *Ascension* offers our valued customers benefits that include; increased component reliability, extended life cycles, and greater resistance from vandalism and weather stresses. The coin track of the *Ascension* AE is similar to the GTE-style housing. In addition, the *Ascension* telephone is designed to mount in panel mount style housings.

Construction of the *Ascension* Telephone

Ascension housings consist of a two-piece cabinet shell constructed of 15 gauge (1.8 mm) deep drawn 1006-carbon steel that contains welded reinforcing members. The primary metalwork (deep draw) is accomplished on an 800-ton press. Extra-heavy 9-gauge steel is used for the vault door, which also incorporates reinforcing members. In order to reduce unauthorized access to the interior of the paystation, tongue-and-groove type construction is used at the mating surfaces of the upper and lower housings and vault door. Case-hardened inner plates that combat attempts to pry or drill into the housing further protect the lower housing and vault door.

Form & Fit of the *Ascension* Telephone

All *Ascension* housing components are 100% tested for proper form, fit, and function prior to shipment. Statistical process control is accomplished through mechanical calibration, measuring, and master samples. High precision machine tools and fixtures provide extremely close tolerances that result in fewer pry points and enhanced weathering characteristics.

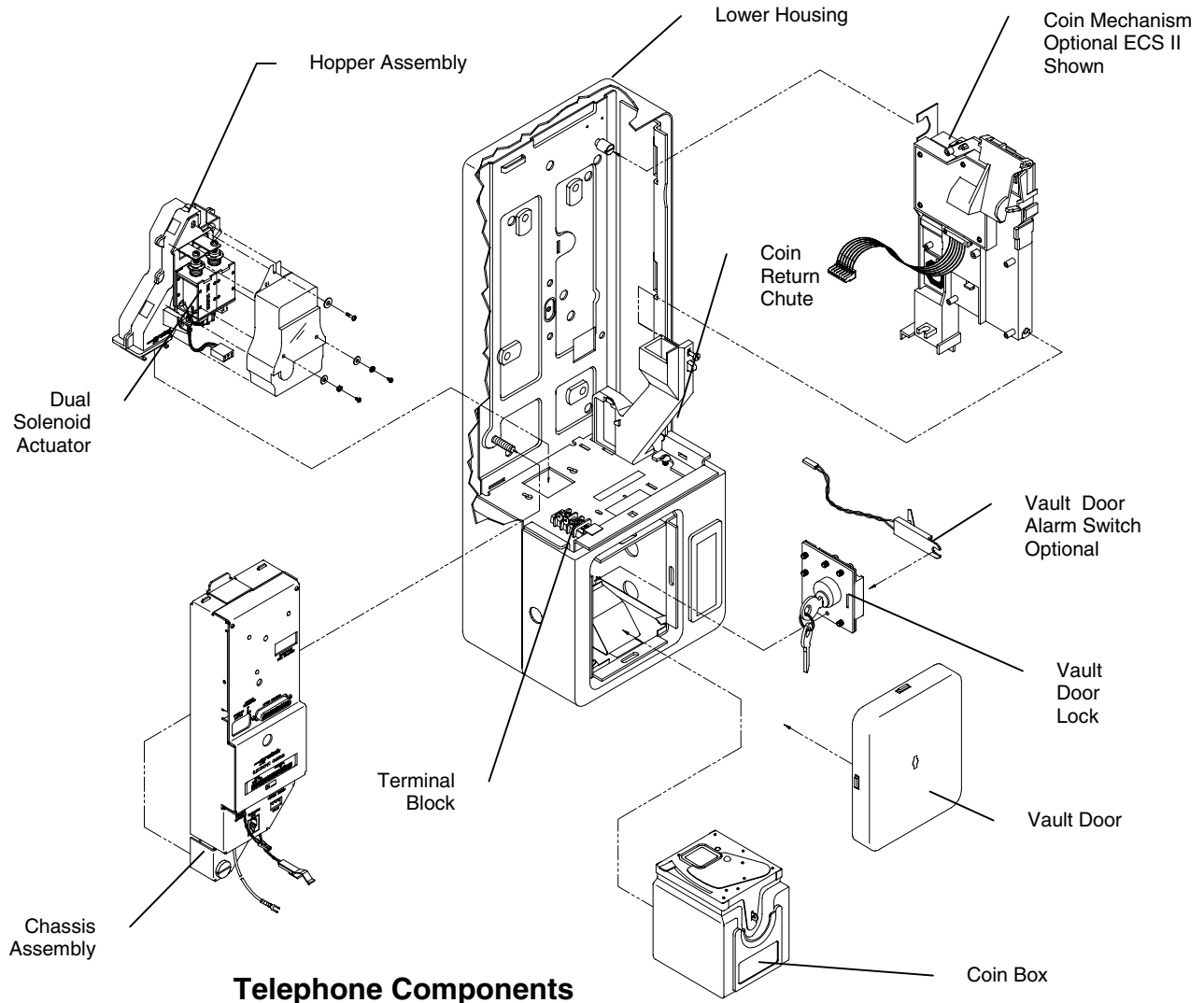

Coin Box w/Lid

This is a standard AE compatible coin box which is dollar coin compatible. The coin box is used to store the coins that are deposited into the telephone.

Vault Door

The vault door is used to enclose the coin box in the telephone and is secured in place by a four-point latching cam mechanism. The vault door latches (bolts) are hardened in order to resist vandalism. The vault door mechanism is nickel-plated for maximum corrosion protection. Vault doors are available in black, stainless steel, or chrome.

Vault Door Lock

The vault door lock is used to lock the vault door in place. It is made by Medeco or Abloy.

Vault Door Alarm Switch

A vault door alarm switch may be installed to monitor entrance to the coin box vault. This switch is mechanically operated with a normally open contact closure.

Terminal Block

The terminal block located inside the lower housing of the phone is used to provide tip & ring signals to the electronic chassis assembly.

Electronic Chassis

The electronic chassis assembly contains the transmission network, coin-control components and logic circuitry. A battery pack and electromagnetic ringer (or optional double gong ringer) are also installed on the board. An optional coin line board may be attached to the chassis assembly to provide the phone with the capability of operating on a standard coin line. The paystation's operating program is stored in downloadable flash memory allowing the phone to be reprogrammed when an update to the phone's operating program becomes necessary. A program button is also provided which allows service personnel to initialize the phone.

Coin Mechanism

Electronic Coin Scanner - ECS II

This kit consists of a simple molded plastic track and an option board for the chassis that provides electronic coin identification and validation functions. The electronic coin scanner recognizes all U.S. coins and most Canadian coins, with the exception of \$2.00 coins.

Coin Mechanism (Mechanical) - Coinco, Imonex

The standard mechanical coin mechanism (rejector mechanism) is a coin testing device that distinguishes coins from slugs that may be encountered in the field. As coins are deposited, the coin mechanism sorts the coins into three general size channels. One channel for quarters, one for nickels and one for dimes. Each deposited coin is checked in its own channel for proper diameter, weight, and thickness. If a coin fails any of the tests, it is diverted to the coin rejector outlet.

Dual Solenoid Actuator/Hopper and Coin Return Chute Assembly

The dual solenoid actuator/hopper and coin return chute assembly serve to relocate coins that are held in the hopper as a result of a coin deposit. A paddle is influenced by the polarity of a voltage applied to the relay. The polarity of the voltage causes the paddle to tilt thus opening the proper trap door causing the phone to collect or refund coins.

Trigger Switch (Not Shown)

If used, the trigger switch provides three separate contact closures for nickel, dime, and quarter deposits. The trigger switch is used with a mechanical coin mechanism.

Latch Assembly

Retention of the upper housing to the lower is effected by two latching steel slide bars that secure at six points which are actuated by the T-wrench. The T-wrench is a one-piece unit of hardened stamped steel.

Hookswitch Cam/Switch Assembly

The *Ascension* incorporates a sealed, two-wire hookswitch assembly that resists corrosion and increases reliability. When the telephone is equipped with a card reading device it is located just under the hookswitch cradle to the left of the main bezel.

Upper Housing Lock

The upper housing lock secures the upper and lower housings of the phone together.

Coin Entrance

The coin entrance fitting is a replaceable unit and is available with various nomenclatures. Currently, the coin entrance can be one of two types. One for 5, 10, and 25 cent coins, and the other for 5, 10, 25, and \$1 coins.

Coin Release Push Button Assembly

The coin release push button, when pushed, causes the telephone to release a jammed deposited coin. Only those coins that have not yet been sent into the coin box will be returned to the customer when the handset is returned to the cradle. The coin return linkage is a stainless steel assembly that is compatible with industry standard coin acceptors.

Handset

Only Protel approved modular handsets should be used in the *Ascension* telephone. Do not assume that any general handset will be compatible with the *Ascension* Telephone. Jumper settings for carbon or dynamic handset operation can be found in Appendix F of this document.

Hookswitch Plate

This cast aluminum cover provides mounting for the hookswitch cradle and hookswitch assembly.

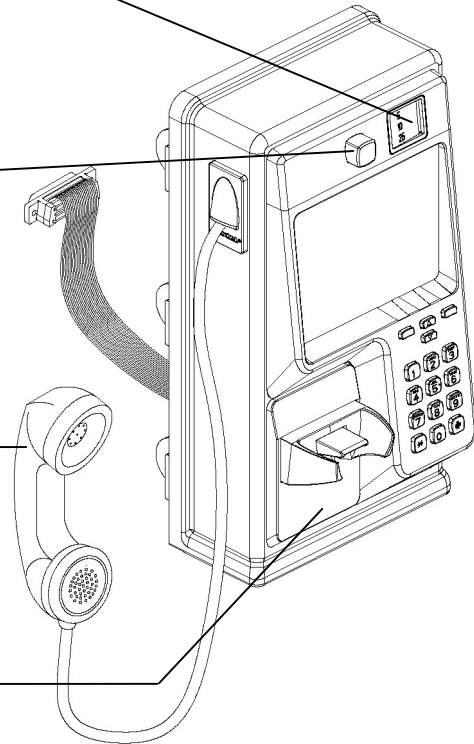
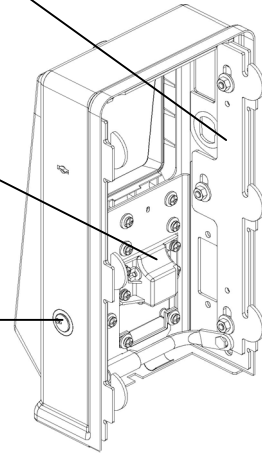

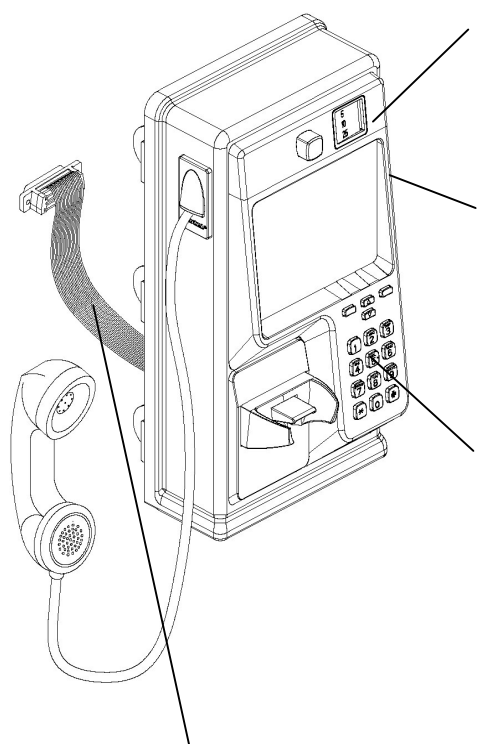

Top Piece

The top piece is located above the main bezel and contains the coin entrance and coin return push button. Custom logos can be designed and silk screened on the top piece.

Main Bezel

The main bezel of the telephone is a chromed, matte finish, cast aluminum with a minimal wall thickness of 0.140". The main bezel is securely fastened to the upper housing at six points to provide strength against vandalism. Impact test performed rated well above industry standards. Test information available by request.

Dial Key Components

One of the main bezel components is the dial keypad. This is a xy matrix printed circuit board that is securely fastened to the back of the main bezel. Additionally, there is a stainless steel push-button retainer plate behind the dial keys to prevent over-travel and reduce vandalism. The dial keys are ergonomically designed for greater customer convenience. The push buttons are cast aluminum, and are also designed to prevent moisture from entering the housing. The '5' key has a raised pip to provide assistance to vision-impaired persons.

Upper Housing Interconnect Cable

This ribbon cable connects the upper housing of the phone to the lower housing.

Information Card

The large information card (4.84" x 6.28", approximately 30.4 sq. in.) which can contain printed instructions (Instructions are determined and printed by customer.) is protected with a clear polycarbonate plastic cover and is reinforced within the telephone by a cast aluminum backing plate. Specifications and installation instructions for the Information Card can be found in Appendix E of this document.

Hookswitch Cradle

Standard GTE style. Easily replaced with four (4) screws.

Dataport Assembly (Optional)

The dataport allows the traveling public to plug their portable computer into the *Ascension* telephone and make toll free calls to their Internet service provider or other computer system. The dataport, when installed, is located conveniently under the dial keypad. Information on installing the dataport can be found in Appendix B of this document. In addition, the *Ascension* must be fitted with a toll restrictor device in order for the dataport to be operational. Information on installing the toll restrictor can be found in Appendix C of this document.

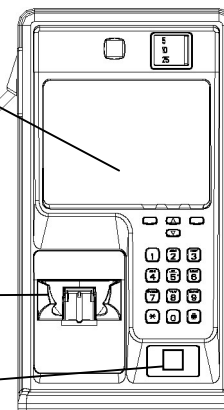

Display Components (Not Shown)

The *Ascension* is capable of accepting a liquid crystal display without external power, a liquid crystal display with external power or a vacuum fluorescent display located in the information card area.

O-Ring Seal

The o-ring seal prevents water from entering into the enclosure. All o-ring seals are made from standard diameter o-ring material.

Cast Aluminum Backing Plate

The backing plate, which mounts inside the upper housing of the phone, provides support to the information card and protects the phone against vandalism.

Function Key Components

The function keys consist of push-buttons, a push-button retainer plate, and a circuit board. The function buttons enhance the use of a full-featured telephone by providing speed dial or other programmed services.

Language Select Button

The language select button is active any time the phone is off hook. Pressing this button will toggle between the Primary Language (PL) and Secondary Language (SL) available in the phone, i.e. – English/Spanish, English/French, etc. The payphone management system will determine which language is used when the phone is taken off-hook. Voice prompts and display messages should be in the same language. The language will change whenever the button is pressed. If it is pressed during a voice prompt, the prompt in progress will be terminated and replayed from the beginning in the new language, and the current message in the display will be redisplayed in the new language.

The on-hook message is user-defined, and is not affected by the language selection button.

Up/Down Volume Control Button

The volume control button is active any time the phone is off hook. The default volume level will continue to be programmable through the management system.

The *Ascension* has both up and down volume control. Pressing the up button will increase the volume by one level. Pressing the down button will decrease the volume by one level. Pressing the up volume button will have no effect if the volume level is already at maximum. Pressing the down volume button will have no effect if the volume level is already at minimum.

Next Call Button

Any time the next call button is pressed, the phone will react as though there has been a loop disconnect.

Only for the following call types will the phone send two seconds of # key DTMF when the next call button is pressed:

- 0+
- 0++
- 10XXXX

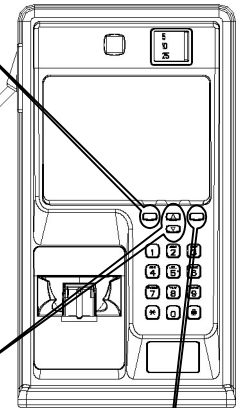

Speed Dial Keys

The full-featured *Ascension* includes five speed dial buttons. Speed dial buttons 1 - 5 correspond with speed dial locations 81 - 85. When a speed dial button is pressed the corresponding speed dial message is displayed on the top line of the display until cutover, at which time the cutover message is displayed.

Displays

All *Ascension* displays have two lines of twenty characters, and are available in either Liquid Crystal or Vacuum Fluorescent. Block mode messaging is used with LC displays. VF displays use a combination of block mode and scrolling messaging.

There are three modes of display operation: on-hook, off-hook, and cutover. On-hook messages are not available for LC displays without external power. To achieve on-hook messaging, the *Ascension* requires external power. Messaging is described fully for each display type.

Conveniently, the messages are programmed in ExpressNet in four 20-character blocks. ExpressNet uses screen 2.2.5.7 to program all display messages. A layout of screen 2.2.5.7 is shown for each display type. Languages in this document are referred to as Primary/Secondary instead of English/Spanish or English/French. For the sake of brevity the primary language will be referred to as PL, and the secondary language will be referred to as SL.

See Appendix I for programming of messages for a LCD with no external power.

See Appendix J for programming of messages for a LCD with external power.

See Appendix K for programming of messages for a VFD.

Card Reader

The card reader of the *Ascension* is capable of reading both magnetic stripe cards and chipcards. Credit cards and calling cards can be used. Chipcard capability is available, but dependent on the user's card type and implementation.

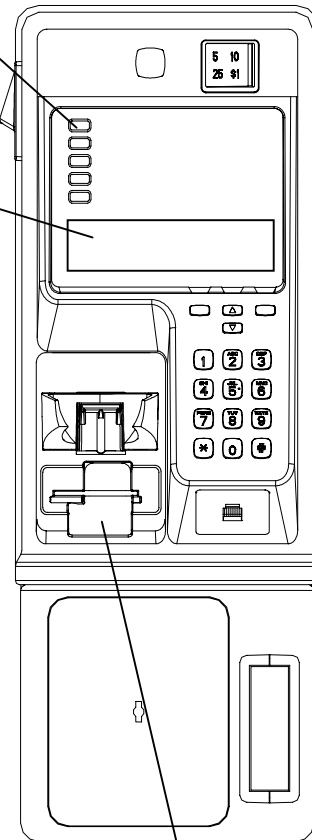

Mounting the Paystation

Mounting Location

This section of the manual details the steps necessary to mount the paystation. The information below should be used as a guideline when considering a suitable location for the installation of the paystation. After the paystation is mounted, initialization and testing procedures should be performed to ensure that the phone is in proper working order before leaving the phone site.

- Location should have sufficient lighting.
- Location should be free from excessive noise, vibration and dirt.
- There should be at least a 6-inch clearance from fluorescent lights, transformers and similar devices to avoid the possibility of inductive interference.

CAUTION!

This telephone comes equipped with a standard 32" armored handset cord. Be advised that the design of the telephone firmly attaches this or any handset cord to the inside of the telephone. It is not designed to break away. If this telephone is installed in a "Drive-up" location, the following notice should be placed in a conspicuous location on the telephone.

**"REMOVE HANDSET AND CORD FROM VEHICLE BEFORE MOVING OR SERIOUS INJURY
COULD RESULT!"**

Leveling the Mounting Surface

The surface on which the paystation is to be mounted will either be a predrilled mounting surface or a backboard specifically designed for the paystation. (If a backboard is to be used, it will be mounted to the location where the phone is being installed.) In either case, it is essential that the paystation be mounted on a surface that is vertically level with a deviation no greater than 1.5 degrees. If the paystation is tilted greater than 1.5 degrees in any direction, there exists the possibility of malfunction of the operation of the phone. Use the information below to measure/adjust the position of the mounting surface. (If the phone is to be mounted in a booth, refer to the booth manufacturer's specifications to determine mounting requirements.)

- Using a level, place the level against either side of the mounting surface (left or right side).
- Move the top or bottom end of the level away from the mounting surface as required to achieve a perfectly vertical reading. (A deviation of zero degrees is desirable but if necessary, 1.5 degrees is acceptable.)
- Adjust the mounting surface as required to achieve a perfectly vertical position.

Mounting the Backboard

If the paystation will be mounted to a predrilled mounting surface, skip this step and proceed to next step – Separating the Upper and Lower Housings.

The mounting surface for the paystation backboard must be flat and free of any peaks or valleys which would cause gaps large enough to allow the phone to be pried loose. Below are the backboard mounting height requirements measured from the floor to the top of the backboard.

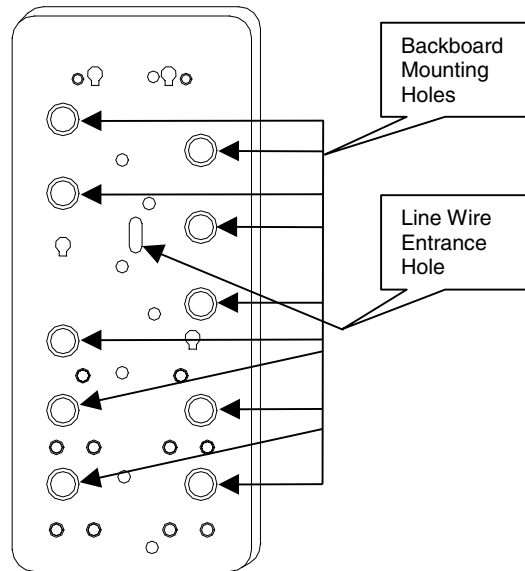

| Top of backboard | Mounting Conditions |
|------------------|---|
| 63" from floor | Without a seat installed |
| 52" from floor | With a seat installed |
| 54" from floor | If a paystation is to be accessed from a wheelchair |

- Route the incoming central office wire such that the end of the wire is positioned through the line wire entrance hole in the backboard. (Be sure that the wire does not become pinched when the backboard is secured to the mounting surface.)
- Mount the backboard to the mounting surface through the ten mounting holes. (See diagram above.) Be sure to use the appropriate hardware for the type of surface that the backboard is being mounted to.

Separating the Upper and Lower Housings

- Insert the key into the upper housing lock and turn it 1/4 turn counter clockwise to the unlock position.
- Insert the T-wrench into the opening in the upper right side of the upper housing and turn it 1/8 turn clockwise.
- Slide the upper housing away from the lower housing far enough to reach inside the left side and then disconnect (if connected) the 25-pin hookswitch/dial assembly connector from the chassis assembly.
- Disconnect the display power and datajack (if installed.)
- Move the upper housing aside.

Removing the Coin Validator

- Disconnect the ECS II connector (if installed) from the point labeled "ELECTRONIC COIN VALIDATOR" on the chassis assembly.
- Remove the screw securing the coin return chute to the coin validator.
- Remove the coin return chute from the lower housing.
- Loosen the captive nut at the top rear of the coin validator.
- Remove the coin validator from the lower housing.

Removing the Chassis Assembly

- (Reference Appendix A for connector locations on the chassis assembly.)
- Disconnect the escrow relay connector from the point labeled "RELAY" on the chassis.
- Disconnect the trigger switch connector (if mechanical coin mechanism is installed) from the point labeled "TRIGGER SWITCH" on the chassis assembly.
- Remove the RJ11 connector from the point labeled "TELEPHONE LINE" on the chassis assembly.
- Disconnect the ground wire from the quick disconnect terminal at the bottom of the chassis.
- Disconnect the vault door alarm connector (if installed).
- Loosen the captive nut at the bottom left of the chassis assembly.
- Remove the chassis assembly from the lower housing by lifting it upward and then pulling out on the lower edge of the chassis assembly.



Removing the Coin Box

- Insert the vault door key into the lock at the left side of the lower housing and turning the key 1/4 turn clockwise to the unlock position.
- Insert the T-wrench into the front of the vault door and turn it 1/8 turn clockwise.
- Remove the vault door away from the lower housing.
- Remove the coin box from the lower housing.

Removing the Escrow Relay/Hopper Assembly

- Loosen the two screws securing the bracket located inside the top of the coin box opening.
- Remove the screw located to the right of the terminal block on the lower housing floor.
- Adjust the bracket on the inside top of the coin box opening until it disengages from the hopper assembly. Then, remove the hopper from the lower housing.

Installing the Security Studs

- Install the four security studs (not provided with phone) through the four threaded holes at the rear of the phone. (See diagram below for security stud locations.)
- Tighten each stud until it is threaded approximately halfway into the hole.

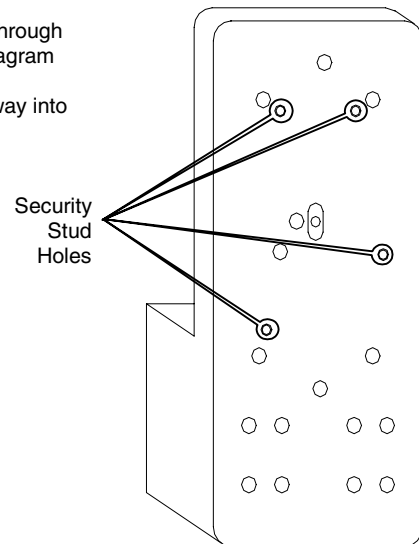
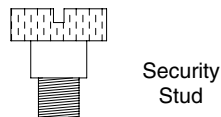

Paystation Rear View

Securing the Paystation to the Mounting Surface

- Route the incoming central office wire such that the end of the wire is positioned through the line wire entrance hole at the rear of the paystation. (Be sure that the wire is positioned such that it does not become pinched when the phone is secured to the mounting surface.)
- Position the paystation on to the mounting surface/backboard such that the four security studs (secured to the phone) are aligned with the four key hole openings in the mounting surface/backboard.
- Guide the paystation downward until the security studs are firmly seated inside the keyholes.
- Tighten the security studs from the inside of the housing by turning them in a counter clockwise direction.
- Secure the paystation to the mounting surface/backboard using eight mounting screws (¼ X 20 X ½ not supplied.) Mounting screw locations are as shown above.

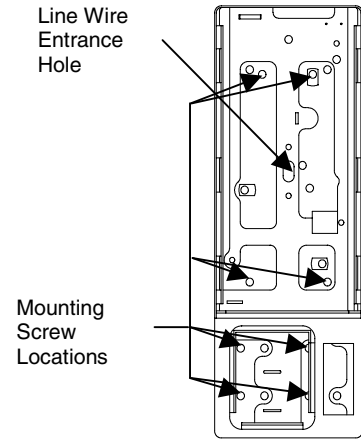

Inside of Paystation

Reinstalling the Escrow Relay/Hopper Assembly

- Position the escrow relay/hopper assembly into the lower housing such that the hopper's coin opening aligns with the access hole in the coin box opening.
- Adjust the bracket inside the top of the coin box opening until the hopper is securely in place.
- Tighten the two screws on the inside top of the coin box opening to secure the bracket.
- Tighten the screw located to the right of the terminal block on the lower housing floor.

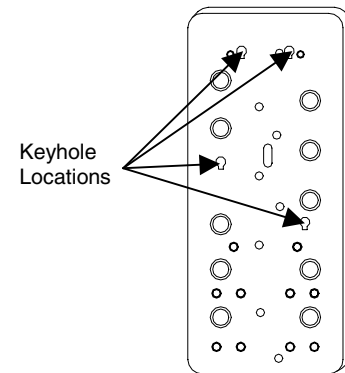

Backboard

Reinstalling the Coin Box

- Reset the coin box lid locking mechanism by opening the lid of the coin box and then turning the lock in a clockwise direction until you hear it click in place.
- Install the coin box into the coin box vault.
- Secure the vault door to the lower housing.

Reinstalling the Chassis Assembly

- Reference Appendix A for connector locations on the chassis assembly.
- Connect the ni-cad battery to the point labeled "BATTERY" on the chassis assembly.
- Install the chassis assembly into the lower housing by guiding the tab at the top rear of the chassis assembly into the slot located at the top left corner inside the phone's lower housing. Then, slide the chassis assembly upward until the captive nut at the bottom left of the chassis assembly is aligned with the mounting stud. Tighten the captive nut.
- Connect the ground wire attached to the quick disconnect spade terminal at the bottom of the chassis assembly, to the middle terminal of the terminal block on the lower housing.
- Connect the RJ11 plug from the terminal block to the point labeled "TELEPHONE LINE" on the chassis assembly.
- Connect the trigger switch connector (if mechanical coin mechanism is installed) to the point labeled "TRIGGER SWITCH" on the chassis assembly.
- Connect the coin relay connector to the point labeled "RELAY" on the chassis assembly. Make sure that the **green** wire is toward the **left** of the connector when plugged in.
- Connect the vault door alarm switch connector (if a vault door alarm switch is installed).

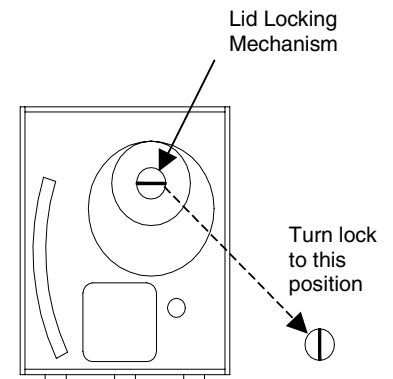

Coin Box Lid – inside view

Reinstalling the Coin Validator

- Position the coin validator into the lower housing by guiding the tab located at the bottom of the validator into the slot just behind the hopper in the lower housing.
- Guide the top of the coin validator into the housing until the notch at the top rear of the validator's mounting bracket fits behind the captive nut.
- Make sure that the coin return chute is mated properly with the hopper and then secure the coin return chute to the coin validator.
- Tighten the captive nut to secure the coin validator in place. NOTE: The captive nut used to hold the coin validator in place has a lip at the rear of the nut. When tightening the nut, make sure that the lip is seated inside the small curve of the opening at the top of the coin validator's mounting bracket. If the lip is not seated properly there will be a space between the back surface of the nut and the front surface of the bracket when the nut is tightened.
- Connect the electronic coin validator connector (if installed) to the point labeled "ELECTRONIC COIN VALIDATOR" on the chassis assembly.

If an electronic coin validator is installed, be very CAREFUL NOT to put any pressure on the white T-shaped plastic flag located on the top right corner of the escrow relay. Putting pressure on this flag may result in a relay jam condition.

Connecting the Line Wire to the Terminal Block

- Connect the incoming C.O. tip wire to the terminal block inside the lower housing. This wire should be connected to the same point as the green wire of the pigtail cable.
- Connect the incoming C.O. ring wire to the terminal block inside the lower housing. This wire should be connected to the same point as the red wire of the pigtail cable.
- Connect the incoming ground wire to the center terminal of the terminal block inside the lower housing. *(Note: Use standard grounding procedures to ensure that the ground wire is at earth ground potential.)*

Connecting the External DC Power

- External power is used to power the display when the phone is on hook. Although a transformer is provided with each *Ascension* a centrally located 24VDC regulated power supply may be used to power several telephones. Please note that 250 mA is required for each *Ascension* with VF display. Additionally, the maximum cable lengths for providing this power are as follows: 350' - 26 awg, 550' - 24 awg, and 880' - 22 awg.
- Make sure that any external power is not connected. The wall transformer (Protel PN: XRP000009) should not be connected to any 120 VAC power source. Also, if a common 24VDC power supply is used, it should not be powered up.
- Route the wires for the external power through the rear panel of the telephone. Position the wires toward the voltage regulator PCB (Protel PN: ASYPWA0238) located at the rear of the terminal block.
- The 24VDC input to the voltage regulator PCB is insensitive to the polarity of the input. Plug the female connector on the end of the wall transformer assembly into J1 on the voltage regulator PCB or connect the wires from the customer provided 24VDC power supply to J2 by lifting both tabs on the connector, inserting the two wires, and pressing the tabs back down.
- Connect one end of the three wire cable (WICA000080) to P1 on the voltage regulator PCB and the other end to the controller board located on the back plate in the upper housing.
- Set the Power On/Off switch on the voltage regulator PCB to the off position.
- Apply 120VAC to the wall transformer or power supply, and position the power on/off switch on the voltage regulator PCB so that Power Good and +5V Good LEDs are illuminated.
- Make sure that the wires are routed properly to insure that they don't get pinched when the upper housing of the phone is connected to the lower housing.
- This completes the steps necessary to mount the paystation. Reference the appropriate sections in the *Ascension* Series Flash 7000 Chassis User's Guide for information on initializing and testing the phone.

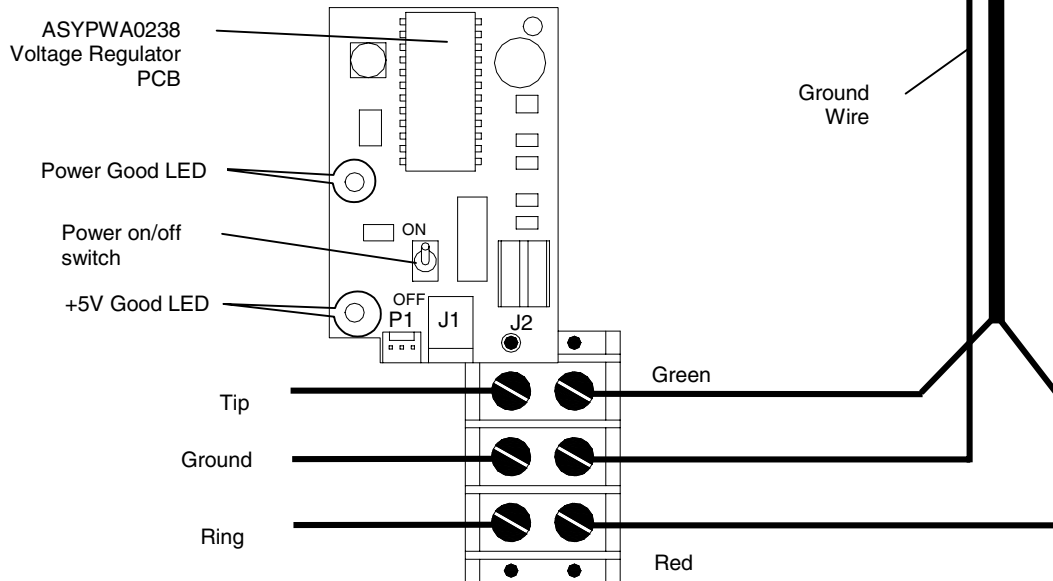
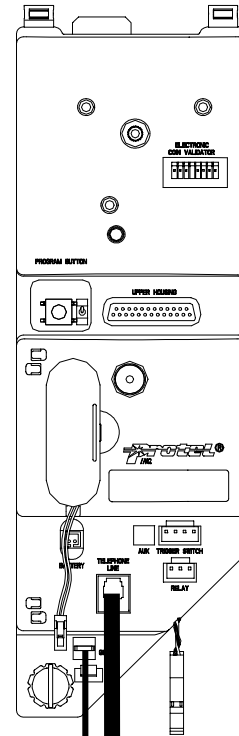

Caution: Always connect and disconnect the power cable to the upper housing with the Power On/Off Switch set to the OFF position.

Connecting the Upper and Lower Housings Together

- If available, use Protel's upper housing parking tool (Protel PN# HDS000004A) to position the upper housing of the phone onto the side of the lower housing. This provides easy access to the phone's internal components while allowing an electrical connection (ribbon cable) between the dial assembly and the chassis assembly (necessary for entering the program mode of the phone). If a parking tool is not available, use the procedure outlined below to connect the dial assembly to the chassis assembly. If a parking tool is available, begin with item "b" in the procedure shown below to connect the dial assembly to the chassis assembly.
- Disconnect the display power and datajack (if installed).
- Rest the upper housing of the phone on the ledge of the lower housing.
- Hold the hookswitch in the on hook position and then connect the 25-pin connector from the interface board at the rear of the dial assembly, to the 25-pin connector labeled "UPPER HOUSING" on the chassis assembly.
- Do not secure the upper and lower housings of the phone together at this time. Access to the program button is needed during the initialization procedure.

Appendix A – 7000C Chassis

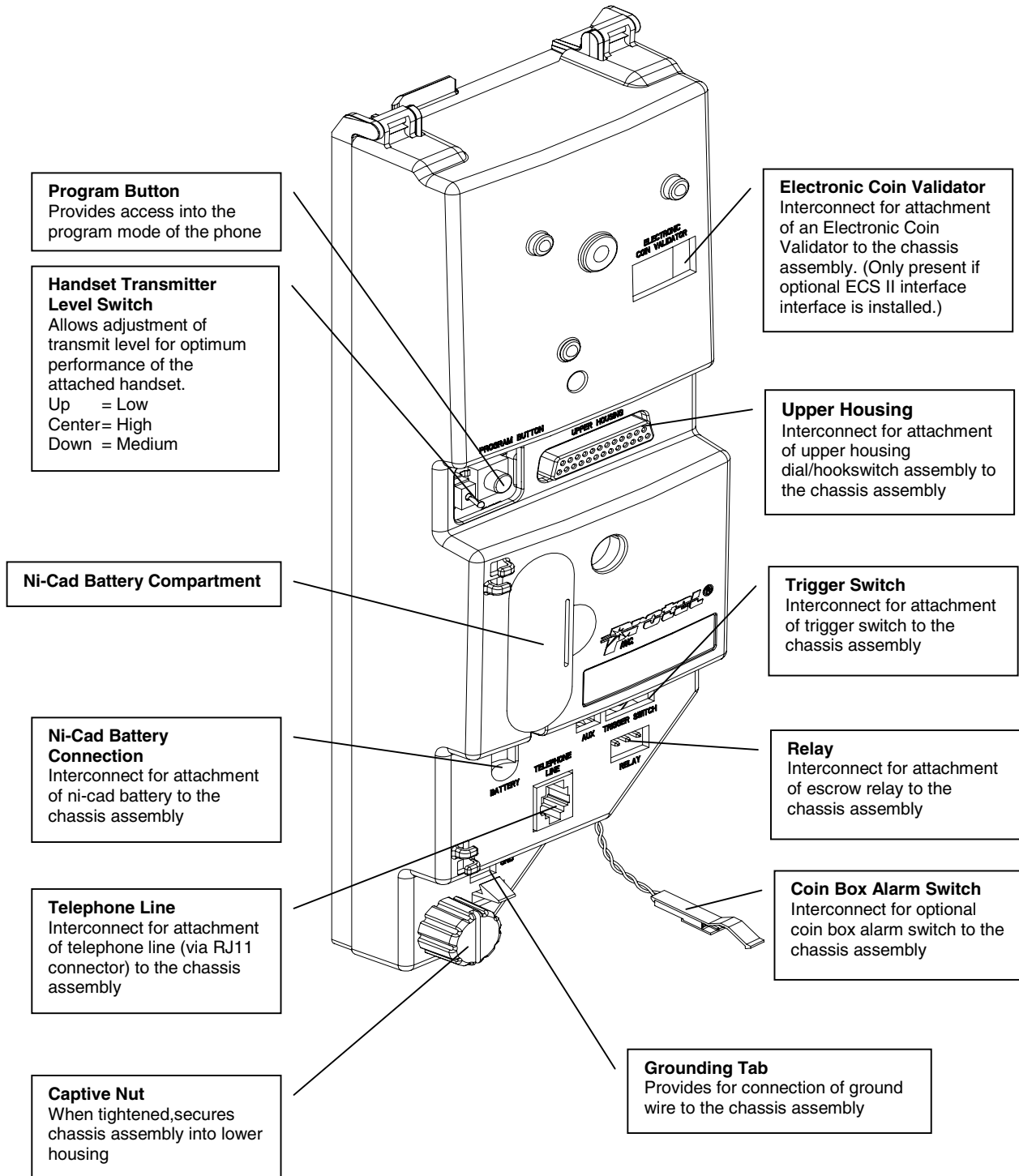

Appendix B – Data Port Installation

The data port allows the traveling public to plug their portable computer into the *Ascension* telephone and make toll free calls to their Internet service provider or other computer systems.

In order for the data port to be operational it must interface with a toll restrictor device that is installed inside the lower housing of the phone. The toll restrictor device can be obtained from Protel or another manufacturer. Instructions for installing the toll restrictor can be found in Appendix C.

Follow the instructions below to install the dataport into the *Ascension* telephone.

Installing the Data Port Assembly

- Separate the upper housing of the phone from the lower housing and disconnect the upper housing interconnect cable from the bottom of the chassis assembly.
- Remove the upper housing from the phone, and remove the upper housing lock guard (if installed) if necessary.
- Loosen the two (2) screws securing the blank locking plate in place.
- Replace the blank plate with a dataport plate.
- Install the dataport jack into the opening in the dataport plate and apply pressure to the jack until it snaps into place within the opening of the plate.
- Tighten the two (2) screws to secure the locking bar in place.

Replacing the Data Port Assembly

- Separate the upper housing of the phone from the lower housing and disconnect the unit coin dial connector or the hookswitch/dial assembly connector from the bottom of the chassis assembly.
- Remove the upper housing from the phone, and remove the upper housing lock guard (if installed) if necessary.
- Loosen two (2) screws and move the locking plate securing the existing dataport in place.
- Remove the old dataport jack from the dataport plate.
- Install the new dataport jack into the opening in the dataport plate and apply pressure to the jack until it snaps into place within the opening of the plate.
- Tighten the two (2) screws to secure the locking bar in place.

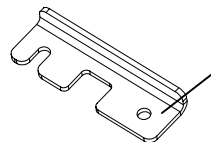
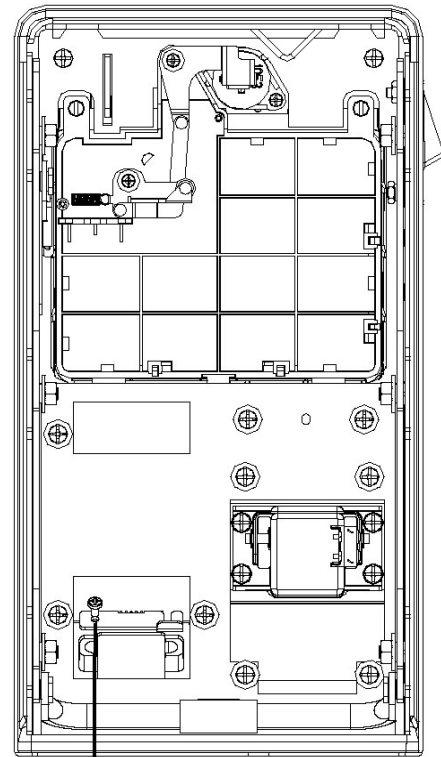

Locking Bar

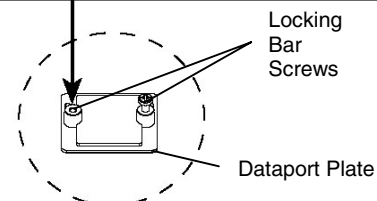

Appendix C – Toll Restrictor Installation

Contact Protel Customer Service at 800-925-8882 to obtain available Toll Restrictor Installation Product Manuals.

Appendix D – Spare Parts List

| Part Description | Protel Part Number |
|--|--------------------|
| Handset, Protel Modular Carbon Handset, 32" PRN00909GB Handset, Protel Modular Dynamic Handset, 32" PRN00910GA (Customer Selected) | |
| Hookswitch Kit (Modified) Hookswitch assembly, and four mounting screws. | KIT0000285 |
| O-Ring Material - 2 meter long piece. | HDS0000217 |
| Keypad Kit 232 pcb, membrane, and four mounting screws. | KIT0000283 |
| Handset Cradle Include four mounting screws. | KIT0000282 |
| Main Bezel Kit Dial keys, impact absorption plate, mounting screws, and gasket. | KIT0000284 |
| Top Piece Assembly Top piece, and coin return mechanism. | PRN00050AA |
| Coin Entrance Kit (5, 10, 25) | KIT0000277 |
| Coin Entrance Kit (5, 10, 25, \$1) | |
| Polycarbonate Lens | HDM0105800 |
| Back Plate Assembly, basic <i>Ascension</i> Back plate with coin release linkage mounted. | ASY0000057 |
| Back Plate Assembly, VFD <i>Ascension</i> | ASY0000073 |
| Card Reader Assembly | ASY0000071 |
| Handset Plate Kit – no card reader | ASY0000061 |
| Handset Plate Kit – with card reader | |
| Chassis Assembly | CTRMNT0155 |
| Coin Mechanism (Customer Selected) | |
| Coin Box (Customer Selected) | |
| Coin Box Switch (Customer Selected) | |
| Anti-Stuffing Device (Customer Selected) | |
| Relay (Customer Selected) | |
| Hopper (Customer Selected) | |
| Reject Chute (Customer Selected) | |
| Vault Door (Customer Selected) | |

Customers are encouraged to note the Customer Selected parts in the space provided. ↑

Appendix E – Information Card Removal, Installation, and Specifications

The large information card (4.84" x 6.28", approximately 30.4 sq. in.), which can contain printed instructions for the telephone, is protected with a clear polycarbonate plastic cover and is reinforced within the telephone by a cast aluminum backing plate. **(Instructions are determined and printed by customer.)**

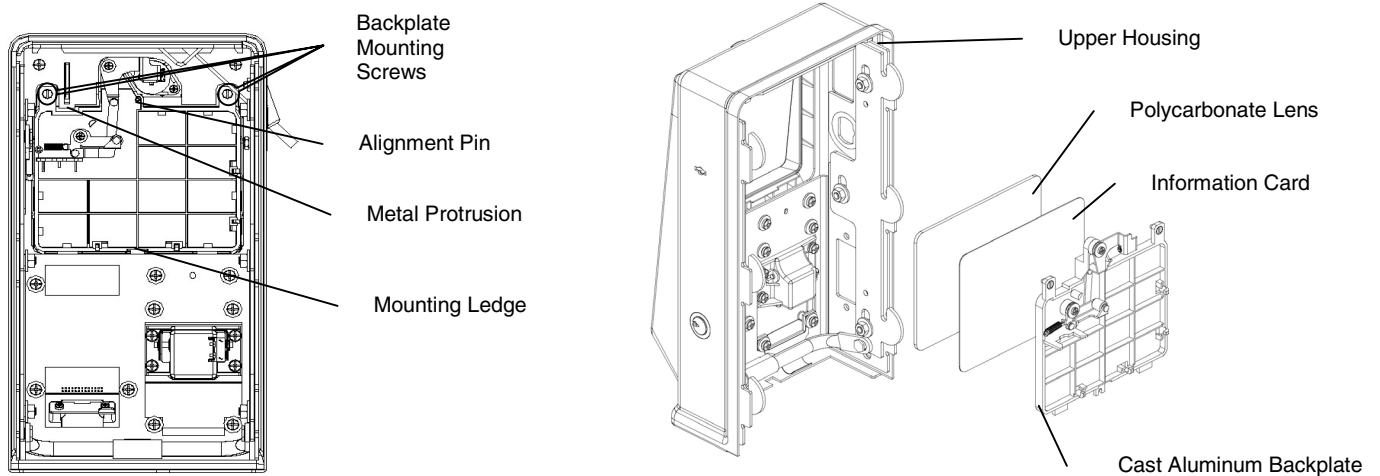

Note: These instructions and diagrams do not show the differences in the backplate assemblies between the basic and full-featured *Ascensions*, however the procedures for both are the same for both. It is recommended that on full-featured *Ascension*, the cable connections to the backplate assembly be removed, and reinstalled after the procedure is finished.

Removal of the Information Card

- Using a flat blade screwdriver loosen the backplate mounting screws while applying a small amount of pressure on the front of the polycarbonate lens until the screws are fully clear of the top piece. Using this method will insure that the captive, backplate mounting screws don't become cross-threaded in the backplate.
- Gently tilt the backplate towards the rear to expose the information card (if present) and the polycarbonate lens.
- Remove the information card.

Installation of the Information Card

- Assuming the backplate has been loosened, insure that the polycarbonate lens is properly located in the main bezel and resting on the mounting ledge at the lower edge of the cutout.
- Insert the information card so that it is located just behind the polycarbonate lens. **Using this method to install the information card provides the easiest method for clearing the metal protrusion located below the coin entrance when positioning the polycarbonate lens and the information card.**
- Position the backplate assembly so that the backplate mounting screws and the alignment pin are properly positioned and tighten the screws.

Basic Dimensions

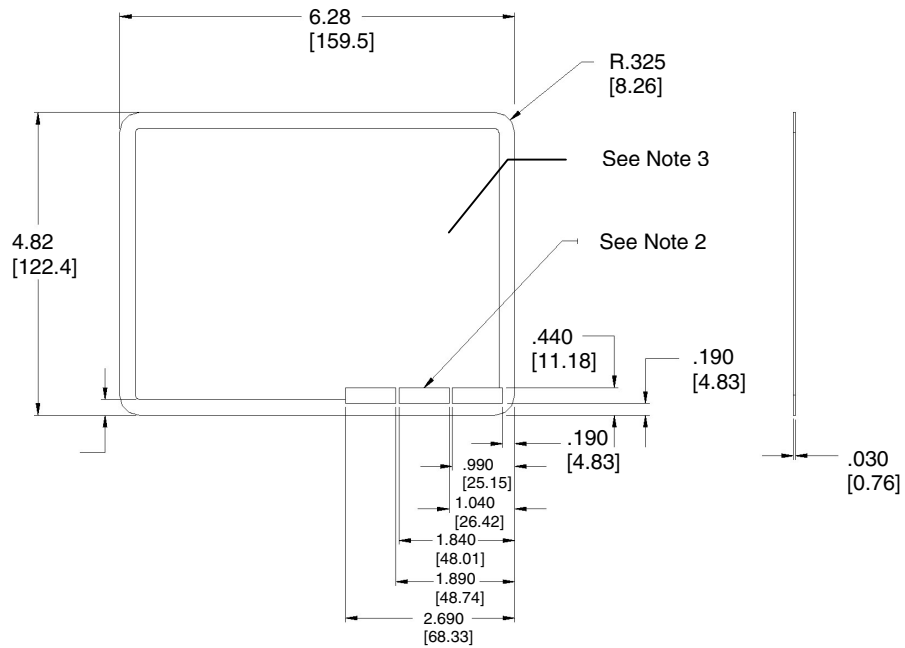

NOTES:

1. Except for "ESPAÑOL", "VOLUME", and "NEXT CALL", nothing closer than .250" from edge.
2. For "ESPAÑOL", "VOLUME", and "NEXT CALL", use black Arial text 6pt (.083) on Yellow Rectangular background Pantone 116.
3. This area of the information card is to be printed to the customer's requirements.

Speed Dial Button and Display Dimensions

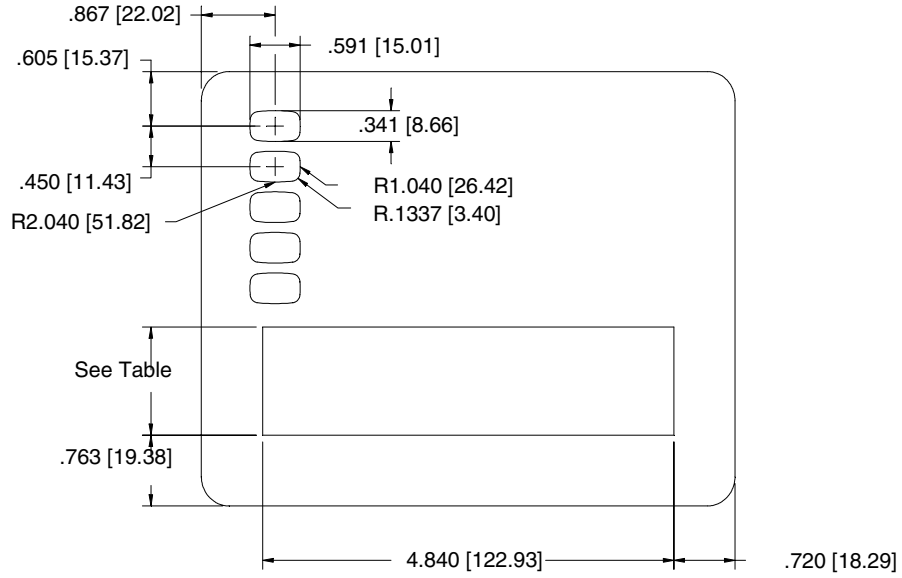

| Part Number | Description | Display Height |
|-------------|----------------------|----------------|
| HDM119600 | Information Card LCD | 1.050 [26.67] |
| HDM119700 | Information Card VFD | 1.200 [30.48] |

Speed Dial Label Dimensions

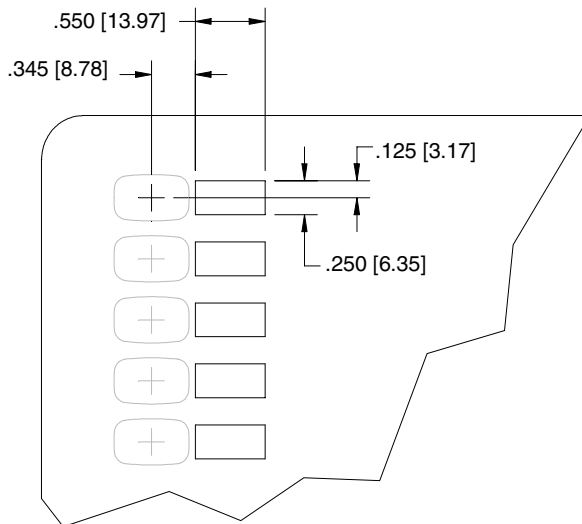

Appendix F – Handset Replacement and Jumper Settings

Replacing the Handset

- Unhook the handset cable from connector P1 on the inside of the upper housing.
- Loosen the thumb screws on the handset entrance locking plate.
- Slide the locking plate downward to release pressure on the armor cable.
- Remove the old handset armor by first removing the lanyard stop from the retaining bracket and then routing the armor lanyard cable through the handset entrance.
- Route the new armor cable lanyard through the handset entrance and continue routing the cable until the lanyard stop is positioned through the retaining bracket hole and secured within the retaining bracket.
- Slide the locking plate upward to apply pressure on the armor cable.
- Tighten the thumb screws on the handset entrance locking plate.
- Reconnect the handset plug to connector P1 on the inside of the upper housing.

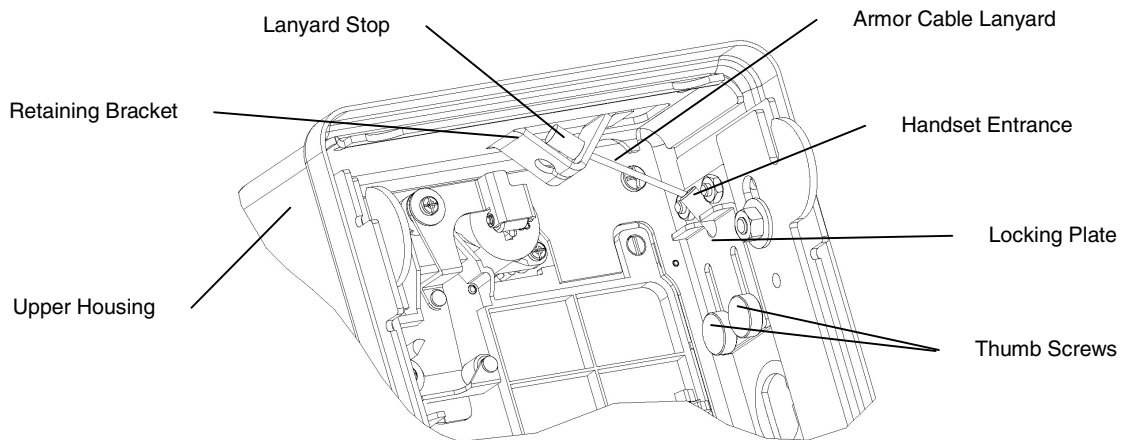

Handset Jumper Settings

Two locations of jumper blocks need to be set for the desired type of handset operation (Carbon or Dynamic). Jumper settings for handset operation are on the chassis assembly as well as inside the upper housing of the phone. Reference the jumper settings below for desired settings. The jumper settings must agree on both the chassis and inside the upper housing.

Handset Jumpers Inside Upper Housing

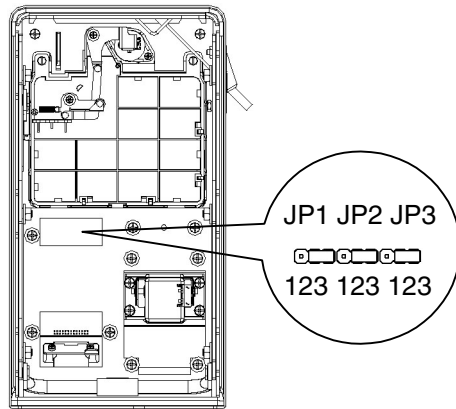

| Carbon | Dynamic |
|-----------|-----------|
| JP1 = 2-3 | JP1 = 1-2 |
| JP2 = 2-3 | JP2 = 1-2 |
| JP3 = 2-3 | JP3 = 1-2 |

Handset Jumper on Chassis Assembly

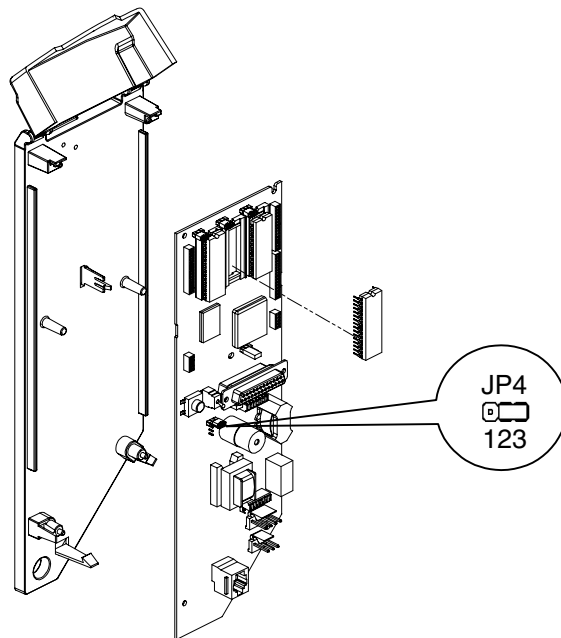

| Carbon | Dynamic |
|-----------|-----------|
| JP4 = 1-2 | JP4 = 2-3 |

Appendix G – Specifications

Electrical

Input Power - Line powered, loop start

Minimum Loop - Basic + ECSII + Credit/Chip Card Reader + Display = 23mA w/Carbon Microphone.
20mA w/Dynamic Microphone

Dialing - Dial pulse or touch tone

DTMF Power Level (LOW Group) -10.5 dBm (min) into 600 ohms

DTMF Power Level (HIGH Group) -8.5 dBm (min) into 600 ohms

DTMF Power Level (per pair) +1.0 dBm (max) into 600 ohms

DTMF Frequency Tolerance $\pm 0.5\%$ per frequency

DTMF Twist ≤ 4 dB

Modem

1200 bit/s DPSK generator, 8 data bits, 2 stop bits and no parity 1200 bit/s FSK generator, 8 data bits, 2 stop bits and no parity 300 bit/s FSK generator, 8 data bits, 2 stop bits and no parity

* (1200 bps DPSK capability requires use of an option board)

* (1200 bps FSK capability requires use of a Protel modem)

Transmit Level -11dBm ± 2 dB (per frequency)

Receive Level 0 to -40 dBm (per frequency)

Coin Tone Frequencies 1700 and 2200 Hz $\pm 1.5\%$

Coin Tone Power Level (per frequency) -4 to -10 dBm into 600 ohms

Coin Tone Twist < 3 dB

Volume Adjust 13.5 dB range in 4.5 dB increments

Hardware

Weight - Approx. 1.1 lbs.

Housing Compatibility - Protel Housings, Palco/Quadrum Housings

Coin Validator Compatibility - GTE-style mechanical industry standard, and Protel ECS II. ***The ECS II requires a Protel designed option interface circuit board.***

Handset Compatibility – Protel modular handsets only. PRN00909GB (Carbon) & PRN00910GA (Dynamic)

WARNING

General handset compatibility must NOT be assumed. Protel approves only handsets listed above.

Dial/Hookswitch Compatibility - Protel *Ascension AE*

Coin Relay Compatibility - Industry standard (48V, 3-wire relay)

Operating Temperature -40°F to +150°F (-40°C to +65°C), -25°C to +65°C card reader, 0°C to +50°C LC Display

Storage Temperature -25°C to +65°C card reader, -20°C to +60°C LC Display

Humidity - 0 to 95% relative, non-condensing

Computer Software - ExpressNet, ExpressNet III, or Panorama Payphone Management software required for communications between the phone and a computer.

Appendix H – Regulatory Information

FCC Registration

This equipment complies with Part 68 of the FCC rules. On the chassis bracket of this equipment is a label that contains, among other information, the FCC Registration Number and Ringer Equivalence Number (REN) for this equipment. If requested, this information must be provided to the telephone company.

The REN is used to determine the quantity of the devices, which may be connected to the telephone line. Excessive REN's on the telephone line may result in the devices not ringing in response to an incoming call. In most but not all areas, the sum of the REN's should not exceed five (5.0). To be certain of the number of devices that may be connected to the line, as determined by the total REN's, contact the telephone company to determine the maximum REN for the calling area.

If the terminal equipment (*Ascension*) causes harm to the telephone network, the telephone company will notify you in advance that temporary discontinuance of service may be required. If advance notice is not practical, the telephone company will notify the Customer as soon as possible. You will also be advised of your right to file a complaint with the FCC if you believe it is necessary.

Direct connection of the equipment to the telephone line may be made only through the use of the furnished standard plug ended cord, to the proper modular jack (i.e. USOC RJ11C).

This equipment (*Ascension*) can not be used on Public Coin Services provided by the telephone company. Connection to Party Line Service is subject to state tariffs. (Contact the state Public Utility Commission, Public Service Commission or Corporate Commission for more information.)

The telephone company may make changes in its facilities, equipment, operations, or procedures that could affect the operation of the equipment (*Ascension*). In this case, the telephone company will provide advance notification in order for you to make the necessary modifications to maintain uninterrupted service.

If trouble is experienced with this equipment (*Ascension*), please contact Protel directly or your authorized Protel Value Added Reseller or Dealer for repair and/or warranty information. If the trouble is causing harm to the telephone network, the telephone company may request that you remove the equipment from the network until the problem is corrected.

This equipment is hearing-aid compatible (HAC) per section 68.316, FCC Rules and Regulations.

For compliance with state tariffs, the telephone company must be notified prior to connection of the equipment (*Ascension*) to the telephone line. In some states, approval for equipment connection must be obtained from the Public Utility Commission, Public Service Commission, or Corporate Commission prior to connection.

FCC Registration No. F2LUSA-20852-CX-E

Ringer Equivalency No. 1.4B

This device complies with Part 15 of the FCC Rules.

Note: This equipment has been tested and found to comply with the limits for a Class A digital device, pursuant to Part 15 of the FCC Rules. These limits are designed to provide reasonable protection against harmful interference when the equipment is operated in a commercial environment. This equipment generates, uses, and can radiate radio frequency energy and, if not installed and used in accordance with the instruction manual, may cause harmful interference to radio communications. Operation of this equipment in a residential area is likely to cause harmful interference in which case the user will be required to correct the interference at his own expense.

This equipment (*Ascension*) is in compliance with the requirements of the **Standard for Telephone Equipment (UL-1459, Second Edition)**. ETL Testing Laboratories in compliance with the above standard list this equipment.

This equipment is capable of providing users access to interstate providers of operator services through the use of access codes. Modification of this equipment by call aggregators to block access dialing codes is a violation of the Telephone Operator Consumers Act of 1990.

Industry Canada Information

Per CP-01 Issue 8 Clause 14.1

NOTICE:

The Industry Canada Label identifies certified equipment. This certification means that the equipment meets telecommunications network protective, operation and safety requirements as prescribed in the appropriate Terminal Equipment Technical Requirements document(s). The Department does not guarantee the equipment will operate to the user's satisfaction.

Before installing this equipment, users should ensure that it is permissible to be connected to the facilities of the local telecommunications company. The equipment must also be installed using an acceptable method of connection. The customer should be aware that compliance with the above conditions may not prevent degradation of service in some situations.

Repairs to certified equipment should be coordinated by a representative designated by the supplier. Any repairs or alterations made by the user to this equipment, or equipment malfunctions, may give the telecommunications company cause to request the user to disconnect the equipment.

Users should ensure for their own protection that the electrical ground connections of the power utility, telephone lines and internal metallic water pipe system, if present, are connected together. This precaution may be particularly important in rural areas.

CAUTION:

User should not attempt to make such connections themselves, but should contact the appropriate electric inspection authority, or electrician, as appropriate.

Per CP-01 Issue 8 Clause 14.2

NOTICE:

The Ringer Equivalence Number (REN) assigned to each terminal device provides an indication of the maximum number of terminals allowed to be connected to a telephone interface. The termination on an interface may consist of any combination of devices subject only to the requirement that the sum of the Ringer Equivalence Number of all the devices does not exceed 5.

Appendix I - Programming of Messages for a LCD with No External Power

In this configuration, the *Ascension* will be completely line-powered. When the phone is on-hook, the display will be blank. When the phone is taken off-hook, the two-line, off-hook message will be displayed for 2.5 seconds. After the off-hook message and prior to cutover, only instruction messages are displayed. After cutover, the upper line of the display is used for instruction messages to the user, and the first 20-character block will be displayed on the bottom line of the display for 2 seconds. Then the second 20-character block will be displayed for 2 seconds, and so forth until all four blocks have been displayed. Any blank block will be skipped. Upon reaching the fourth block this process will be repeated. This messaging technique will continue until the phone is placed on-hook, or until the user initiates a new call. After cutover, the cutover message will always be displayed.

| Screen 2.2.5.7 Layout for LCD – NO EXTERNAL POWER | | | |
|---|----------------------------------|------------|---------------------------|
| Programmable Messages | | | |
| Select-A-Carrier | | Card Route | |
| 1 | Upper line, PL, off-hook message | 1 | Speed dial 1 label |
| 2 | Lower line, PL, off-hook message | 2 | Speed dial 2 label |
| 3 | Block 1, PL, block message | 3 | Speed dial 3 label |
| 4 | Block 2, PL, block message | 4 | Speed dial 4 label |
| 5 | Block 3, PL, block message | 5 | Speed dial 5 label |
| 6 | Block 4, PL, block message | 6 | N/A |
| 7 | Upper line, SL, off-hook message | 7 | N/A – no on-hook messages |
| 8 | Lower line, SL, off-hook message | 8 | N/A – no on-hook messages |
| 9 | Block 1, SL, block message | 9 | N/A – no on-hook messages |
| 10 | Block 2, SL, block message | 10 | N/A – no on-hook messages |
| 11 | Block 3, SL, block message | 11 | N/A |
| 12 | Block 4, SL, block message | 12 | N/A |

Reference Function Key Components for Explanation of Primary and Secondary Languages.

Appendix J - Programming of Messages for a LCD with External Power

In this configuration, when the phone is on-hook, the display will display block 1 of the on-hook message for 2 seconds, followed by block 2 of the on-hook message. *Note: Each block of the LC on-hook message contains two lines.* While the phone is on-hook this will be repeated. When the phone is taken off-hook, the two-line off-hook message will be displayed for 2.5 seconds. After the off-hook message and prior to cutover, only instruction messages are displayed. After cutover, the upper line of the display is used for instruction messages to the user. The bottom line of the display will display block 1 of the on-hook message for 2 seconds, followed by block 2 for 2 seconds, then block 3 for 2 seconds, and finally block 4 for 2 seconds. After the fourth block this process will be repeated. This messaging technique will continue until the phone is placed on-hook, or until the user initiates a new call. Any blank block will not be displayed. After cutover, the cutover message will always be displayed.

| Screen 2.2.5.7 Layout for LCD – WITH EXTERNAL POWER | | | |
|---|----------------------------------|------------|--------------------------------------|
| Programmable Messages | | | |
| Select-A-Carrier | | Card Route | |
| 1 | Upper line, PL, off-hook message | 1 | Speed dial 1 label |
| 2 | Lower line, PL, off-hook message | 2 | Speed dial 2 label |
| 3 | Block 1, PL, block message | 3 | Speed dial 3 label |
| 4 | Block 2, PL, block message | 4 | Speed dial 4 label |
| 5 | Block 3, PL, block message | 5 | Speed dial 5 label |
| 6 | Block 4, PL, block message | 6 | N/A |
| 7 | Upper line, SL, off-hook message | 7 | Block 1, upper line, on-hook message |
| 8 | Lower line, SL, off-hook message | 8 | Block 1, lower line, on-hook message |
| 9 | Block 1, SL, block message | 9 | Block 2, upper line, on-hook message |
| 10 | Block 2, SL, block message | 10 | Block 2, lower line, on-hook message |
| 11 | Block 3, SL, block message | 11 | N/A |
| 12 | Block 4, SL, block message | 12 | N/A |

Reference Function Key Components for Explanation of Primary and Secondary Languages.

Appendix K - Programming of messages for a VFD

In this configuration, when the phone is on-hook, the top line of the display will display block 1 of the on-hook message for 2 seconds, followed by block 2 for 2 seconds, then block 3 for 2 seconds, and finally block 4 for 2 seconds. **Note: Each block of the VF on-hook message contains one line.** Also, on the bottom line, the 80-character, PL scrolling message will be displayed with a step rate of 125 milliseconds. While on-hook this messaging technique will be repeated.

When the phone is taken off-hook, the two-line off-hook message will be displayed for 2.5 seconds. After the off-hook message and prior to cutover, only instruction messages are displayed.

After cutover, the upper line of the display is used for instruction messages to the user. On the bottom line of the display the appropriate scrolling message across the lower line of the display with a step rate of 125 milliseconds. After cutover, the cutover message will always be displayed. This messaging technique will continue until the phone is placed on-hook, or until the user initiates a new call.

| Screen 2.2.5.7 Layout for VFD | | | |
|-------------------------------|------------------------------------|------------|--------------------------|
| Programmable Messages | | | |
| Select-A-Carrier | | Card Route | |
| 1 | Upper line, PL, off-hook message | 1 | Speed dial 1 label |
| 2 | Lower line, PL, off-hook message | 2 | Speed dial 2 label |
| 3 | Bytes 1-20, PL, scrolling message | 3 | Speed dial 3 label |
| 4 | Bytes 21-40, PL, scrolling message | 4 | Speed dial 4 label |
| 5 | Bytes 31-60, PL, scrolling message | 5 | Speed dial 5 label |
| 6 | Bytes 61-80, PL, scrolling message | 6 | N/A |
| 7 | Upper line, SL, off-hook message | 7 | Block 1, on-hook message |
| 8 | Lower line, SL, off-hook message | 8 | Block 2, on-hook message |
| 9 | Bytes 1-20, SL, scrolling message | 9 | Block 3, on-hook message |
| 10 | Bytes 21-40, SL, scrolling message | 10 | Block 4, on-hook message |
| 11 | Bytes 31-60, SL, scrolling message | 11 | N/A |
| 12 | Bytes 61-80, SL, scrolling message | 12 | N/A |

Reference Function Key Components for Explanation of Primary and Secondary Languages.

Index

- Alarm Switch
 - vault door, 4
- Back Plate
 - description, 8
- Backing Plate
 - description, 8
- Bezel
 - description, 7
- Chassis Assembly
 - installing, 13
 - removing from phone, 12
- Coin Box
 - installing, 13
 - removing from phone, 12
- Coin Mechanism
 - Mechanical
 - description, 4
- Coin Return
 - description, 5
- Coin Validator
 - installing, 14
 - removing from phone, 11
- Components
 - back plate, 8
 - bezel - main, 7
 - coin mechanism mechanical, 4
 - coin return, 5
 - dataport assembly, 7
 - display, 8
 - electronic chassis, 4
 - hookswitch assembly, 5
 - hookswitch plate, 6
 - latch assembly, 5
 - lock - upper housing, 5
 - o-ring seal, 8
 - terminal block, 4
 - top piece, 7
 - vault door, 3
 - vault door lock, 4
- Dataport
 - description, 7
- Display
 - description, 8
- Electronic Chassis
 - description, 4
- Escrow Relay
 - installing, 13
 - removing from phone, 12
- Handset
 - replacing, 23
- Hookswitch
 - description, 5
 - plate
 - description, 6
- Housing
 - connecting, 16
 - separating upper & lower, 11
- Latch Assembly
 - description, 5
- Line Wire
 - connection on terminal block, 14
- Lock
 - upper housing
 - description, 5
- Mounting
 - securing the phone, 13
 - the backboard, 11
- O-Ring Seal
 - description, 8
- Security Studs
 - installing, 12
- Terminal Block
 - description, 4
 - wire connections, 14
- Top Piece
 - description, 7
- Vault Door
 - description, 3
- Vault Door Lock
 - description, 4

